

### Static Dimensions

Machine model	540-140
	m (ft-in)
A Overall height	2.59 (8-6)
B Overall width (over tyres)*	2.35 (7-9)
C Inside width of cab	0.94 (3-1)
D Front track	1.90 (6-3)
E Wheelbase	2.90 (9-6)
F Overall length to front tyres	5.18 (17-0)

\*Dependant upon tyre specified.

Machine model	540-140
	m (ft-in)
G Overall length to front carriage	6.25 (20-6)
H Ground clearance	0.40 (1-4)
Outside turn radius (over tyres)	4.10 (13-5)
Weight	kg (lb) 10858 (23934)
Tyres	15.5-25

## Lift Performance – Stabilisers Extended

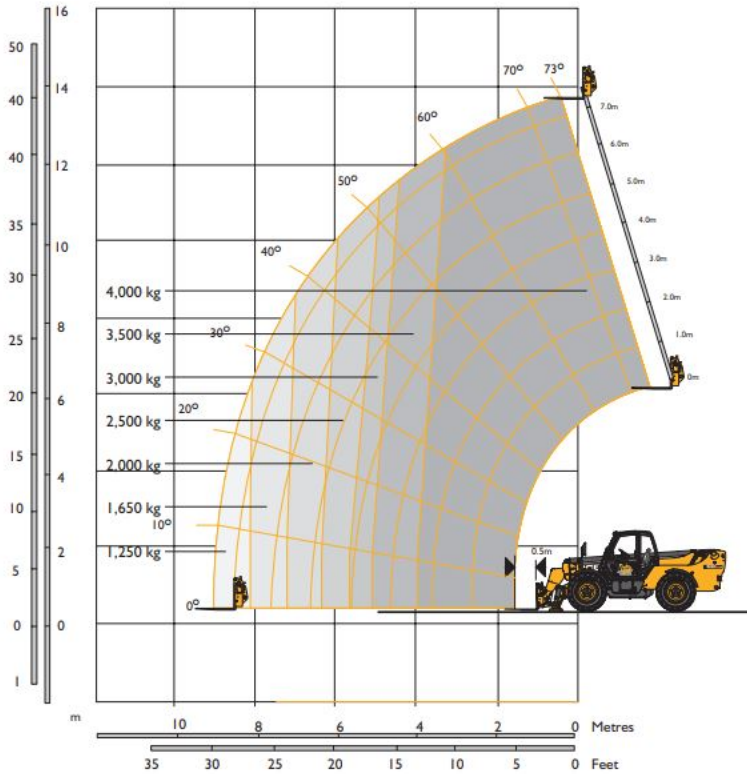

## Lift Performance – Stabilisers Extended – 540-140

Machine Model		540-140
Maximum lift capacity	kg (lb)	4000 (8818)
Lift capacity to full height	kg (lb)	4000 (8818)
Lift capacity at full reach	kg (lb)	1250 (2756)
Lift height	m (ft-in)	13.8 (45-3)
Reach at maximum lift height	m (ft-in)	0.74 (2-5)
Maximum forward reach	m (ft-in)	9.25 (30-4)
Reach with 1 tonne load	m (ft-in)	9.25 (30-4)
Placing Height	m (ft-in)	13.25 (43-6)

Complies with stability test EN1459 annex B. Lift heights are with stabilisers fully extended.

## Lift Performance – Stabilisers Retracted

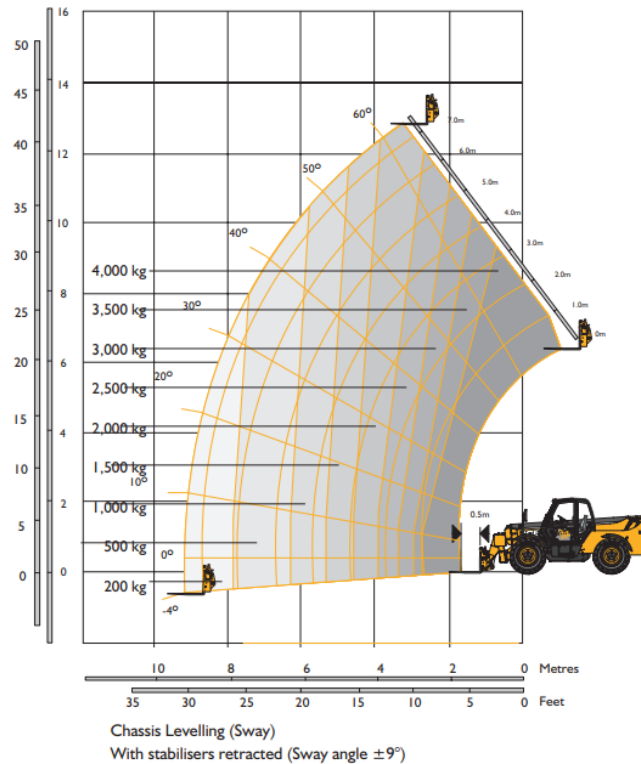

## Lift Performance – Stabilisers Extended – 540-140

Machine Model		540-140
Maximum lift capacity	kg (lb)	4000 (8818)
Lift capacity to full height	kg (lb)	2000 (4410)
Lift capacity at full reach	kg (lb)	200 (441)
Lift height	m (ft-in)	12.82 (42-1)
Reach at maximum lift height	m (ft-in)	2.94 (9-8)
Maximum forward reach	m (ft-in)	9.25 (30-4)
Reach with 1 tonne load	m (ft-in)	6.25 (20-6)
Placing Height	m (ft-in)	12.25 (40-2)

Complies with stability test EN1459 annex B.

## Engine

Latest technology and advanced design provides low fuel consumption, reduced noise, high torque and power output, total reliability and minimal maintenance.

Two-stage, dry type air filter with primary and safety elements.

Machine Model		Standard	Option	Option
Displacement	ltr (in <sup>3</sup> )	4.4 (269)	4.4 (269)	4.4 (269)
No. of cylinders		4	4	4
Bore size	mm (in)	105 (4.13)	105 (4.13)	105 (4.13)
Stroke	mm (in)	127 (5)	127 (5)	127 (5)
Aspiration		Naturally aspirated	Turbo	Turbo intercooled
<b>Power rating</b>				
Power @ 2200rpm	kW (HP)	62.0 (82.5)	74.5 (100)	90.5 (121)
<b>Torque rating</b>				
Torque	Nm (lbf ft)	308 (227)	415 (306)	434 (320)

## Transmission

JCB powershift transmission incorporating torque converter, bevel box and a 4 speed powershift gearbox in one resiliently mounted unit.

A combined steering column mounted switch incorporating directional control and 4 forward and 4 reverse powershift gears. Travel speed 25kph (16mph).

**Front and rear drive axles:** JCB epicyclic hub reduction drive/steer axles with Max-Trac torque proportioning differentials. Permanent 4 wheel drive.

## Brakes

**Service brakes:** Hydraulically activated, self-adjusting, oil-immersed in-board multi-disc type on front axle.

**Parking brake:** Hand operated disc brake on output of gearbox.

## Boom and Carriage

Boom is manufactured from high tensile steel.

Low maintenance, hard wearing pads.

JCB Q-fit self-levelling carriage with lever operated pin locking accepts pallet forks and a wide range of attachments.

One boom end auxiliary hydraulic service fitted as standard.

## Safety Check Valves

Fitted to carriage tilt, telescopic and boom lift rams.

## Service Capacities

Fuel tank	litres (UK gal)	125 (27.5)
Hydraulic tank	litres (UK gal)	131 (28.2)
Coolant	litres (UK gal)	23 (5.1)

## Hydraulics

Two stage gear pump with suction strainer and filter.

Operating system pressure	bar (psi)	241 (3500)
Main Hydraulics	ltrs/min	110
<b>Hydraulic Cycle Times</b>		<b>Seconds</b>
Boom raise		14.2
Boom lower		11.9
Extend		22.3
Retract		18.6
Bucket dump		2.4
Bucket crowd		3.2

## Electrics

12 v negative earth. 130 AH battery. 95 amp alternator. Full road lighting. Reversing light. Direction indicators. Hazard warning. Reverse alarm.

## Cab

Quiet safe and comfortable cab conforms to ROPS ISO 3471 and FOPS ISO 3449. Tinted glass all round. Laminated roof screen. Roof bars, front, rear and roof screen wash/wipe and heater/screen demister. Opening rear window. Audio-visual warning system for coolant temperature, engine oil pressure, air cleaner, battery charge, transmission oil temperature and pressure, water in fuel. Hourmeter and road speed indicator. Engine temperature, fuel gauge and inclinometer.

Mechanical joystick, direct acting hydraulic control levers. Adjustable steer column with stalk bar powershift change and forward reverse shuttle. Throttle and brake pedal. Adjustable deluxe seat with adjacent park brake fitted.

Automatic eye level audio-visual load moment indicator warning system receiving a signal from a load sensor on the rear axle.

This system continuously monitors the machine's forward stability and leaves the operator in control at all times.

Optional indicator lamp to show when the stabilisers are on firm ground.

Safety canopy as above but with side glass and roof glass only (screen wiper and heater/screen demister not applicable).

## Steering

Hydrostatic power steering.

Three steer mode options: front wheel steer; all wheel steer; crab steer: operated from in the cab by a selection switch, or with automatic alignment.

## Options and Accessories

**Options:** Front and rear working lights, rotating flashing beacon, fire extinguisher, radial industrial tyres, electrical 2/4WD select, limited slip differential in front axle, windscreen and roof guard, air suspension seat, deluxe cab trim, no smoking pack, roof and front screen blind, radio kit, heavy duty battery, air conditioning, clearview carriage, sideshift.

**Attachments:** Contact your local dealer for details of the comprehensive range.