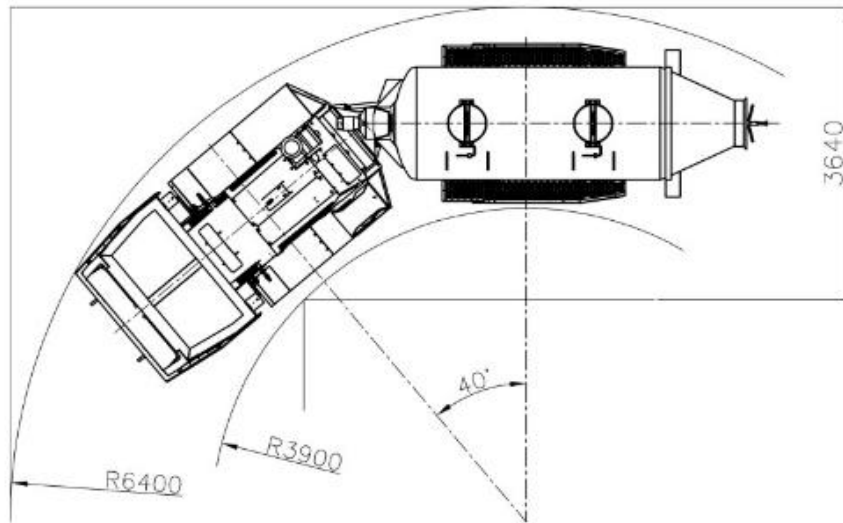
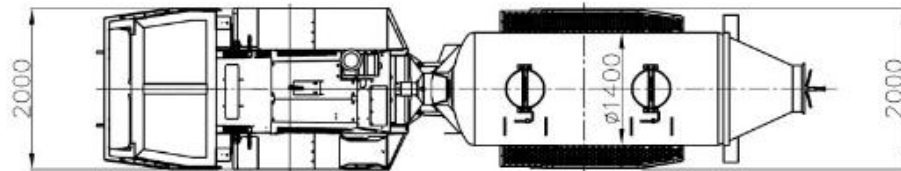

**normet**

Normet Corporation  
 Ahmolan tie 6  
 FI-74510 IISALMI, FINLAND  
 Tel +358 (0) 17 83 241  
 Fax +358 (0) 17 823 606

**Variomec 1050 M**

TI 1800016  
 DRW  
 DATE 04.12.2007  
 PAGE 2 / 3  
 APPR. 07.05.2009

**normet**

Normet Corporation  
 Ahmolan tie 6  
 FI-74510 IISALMI, FINLAND  
 Tel +358 (0) 17 83 241  
 Fax +358 (0) 17 823 606

**Variomec 1050 M**

TI 1800016  
 DRW  
 DATE 04.12.2007  
 PAGE 3 / 3  
 APPR. 07.05.2009

**DIMENSIONS**

Length 9050 mm  
 Width 2000 mm  
 Height 2550 mm  
 Wheel base 3650 mm  
 Track 1650 mm  
 Ground clearance 360 mm

**WEIGHT**

Operating 10400 kg

**TURNING RADIUS**

Outer 6400 mm  
 Inner 3900 mm

**MIXER**

Drum volume (100% fill) 5,5 m<sup>3</sup>  
 Carrying capacity 4,4 m<sup>3</sup>  
 Hydraulically controlled mixing and unloading  
 Adjustable rotation speed 0...13 rpm

**PERFORMANCE CURVE**

17100043  
 1st gear max. 5 km/h  
 2nd gear 10 km/h  
 3rd gear 25 km/h  
 Max. tractive effort 132 kN

**TRANSMISSION**

Dana Spicer powershift  
 3 speeds forwards and reverse  
 4-wheel drive

**AXLES**

Planetary type  
 rear axle fixed  
 front axle oscillation +/- 10°

**TYRES**

12.00 - 20 PR 18

**BRAKES**

**Service brake:** hydraulically powered two-circuit oil immersed multidisc brakes in both axles  
**Safety/Parking brake:** hydraulically released fail-safe - type brake

**STEERING**

Hydraulic frame steering,  
 Orbital type  
 Frame articulation +/- 40°

**HYDRAULICS**

190 bar, 100 l/min/2200 rpm  
 for steering and brakes  
 200 bar, 105 l/min/2200 rpm for mixer

**ENGINE**

Deutz TCD 2013 L4  
 120 kW/2300 rpm

**ELECTRICAL SYSTEM**

24 V negative ground  
 Battery 2 x 110 Ah  
 Alternator 80 A  
 Lights (2+2) x 70 W

**OPTIONS AND ACCESSORIES:****ENCLOSED CABIN****CABIN HEATING****AIR CONDITIONING****ENGINE**

MB 904 LA  
 110 kW/2200 rpm

**RETARDER**

Mounted in driveline  
 Electromagnetic type  
 Recommended on inclines deeper than 1:10 and longer than 1000 m

**HIGH PRESSURE WASHER**

Hydraulically operated  
 Washing effect 10 kW  
 Max. input water temperature 200 bar/30 l/min + 70°C

**MIST SPRAY**

**normet**

Normet Corporation  
Ahmolan tie 6  
FI-74510 IISALMI, FINLAND  
Tel +358 (0) 17 83 241  
Fax +358 (0) 17 823 606

## Variomec 1050 M

TI 1800016  
DRW  
DATE 04.12.2007  
PAGE 1 / 3  
APPR. 07.05.2009

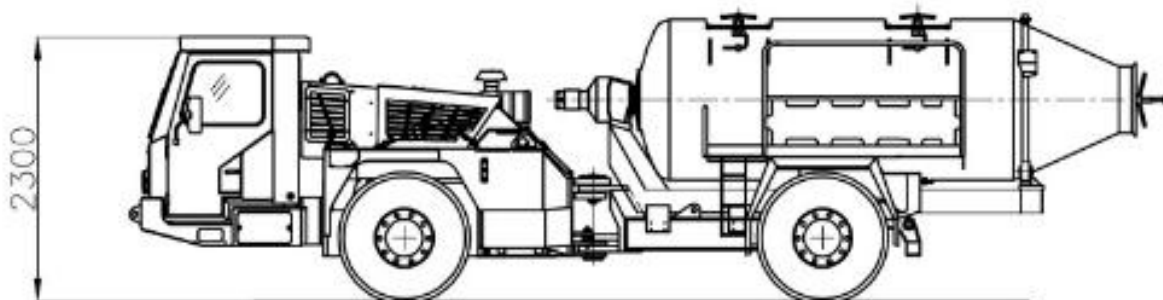
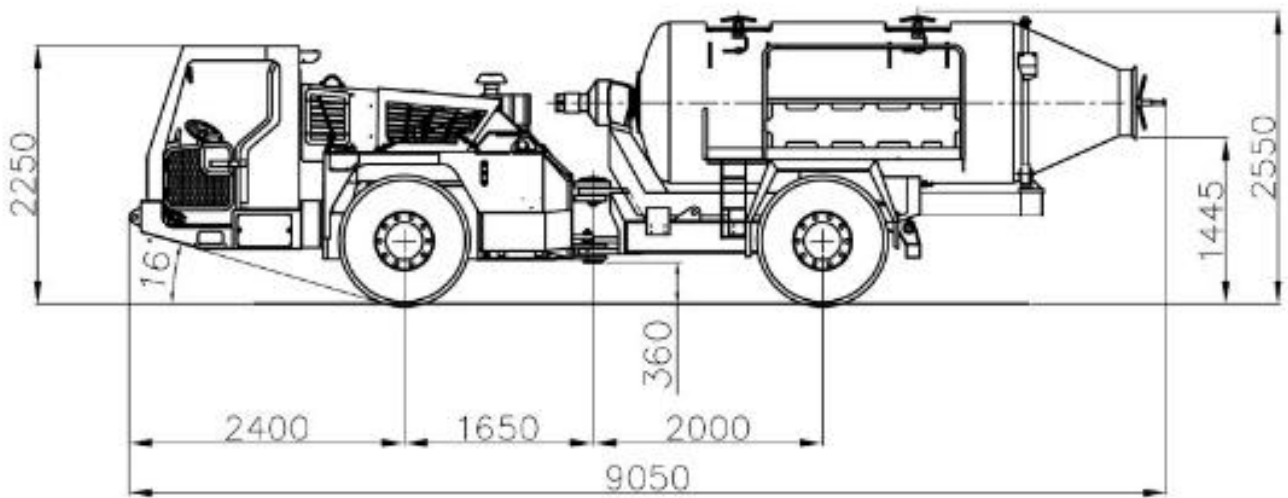

2300