

# EXCAVATOR BRUSH FLAIL MOWER

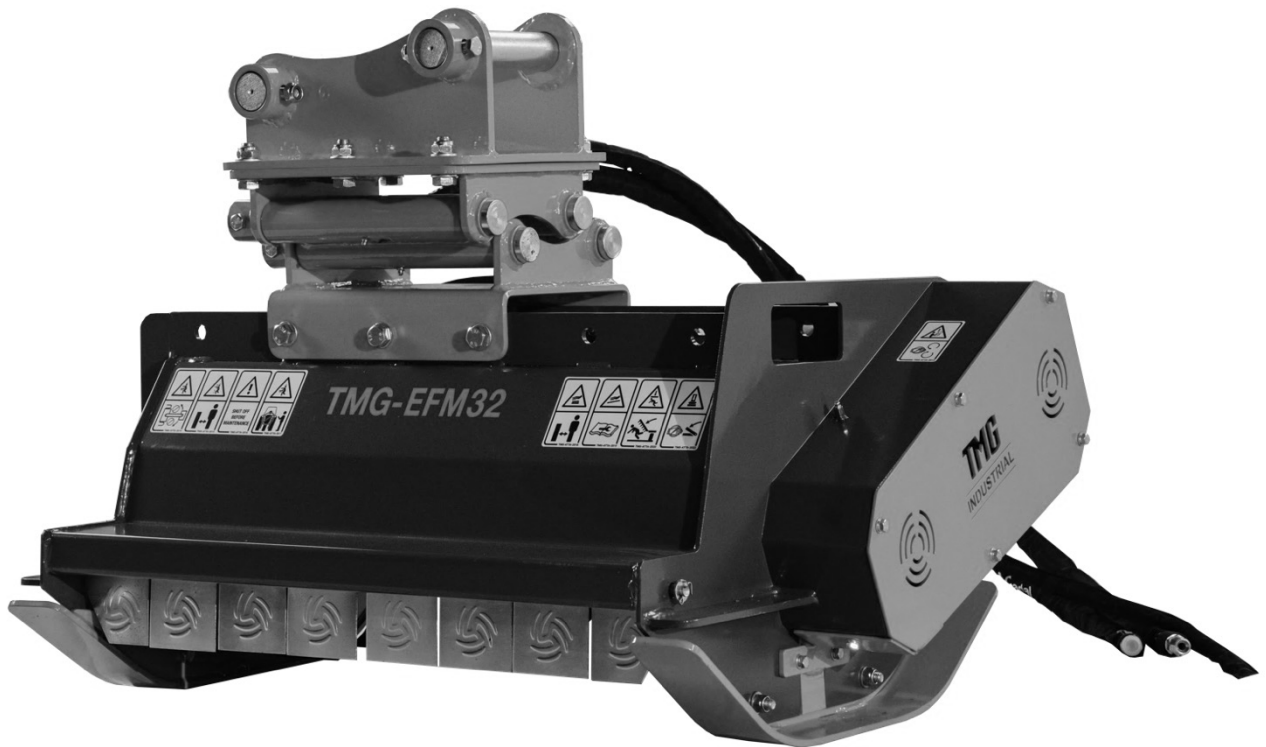

### ⚠ WARNING

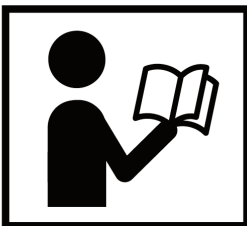

- Please read and understand the product manual completely before assembly
- Check against the parts list to make sure all parts are received
- Wear proper safety goggles or other protective gears while in assembly
- Do not return the product to dealer. They are not equipped to handle your requests.

Missing parts or have questions on assembly?

Please call: 1-877-761-2819 or email: [cs@tmgindustrial.com](mailto:cs@tmgindustrial.com)

# CONTENTS

<b>IMPORTANT SAFETY INFORMATION</b> .....	<b>3</b>
<b>YOUR SAFETY</b> .....	<b>3</b>
<b>GENERAL SAFETY</b> .....	<b>3</b>
<b>EQUIPMENT SAFETY GUIDELINES</b> .....	<b>4</b>
<b>SAFETY TRAINING</b> .....	<b>5</b>
<b>SAFETY SIGNS</b> .....	<b>5</b>
<b>SAFETY DECALS</b> .....	<b>6</b>
.....	<b>6</b>
<b>PREPARATION</b> .....	<b>6</b>
<b>MAINTENANCE SAFETY</b> .....	<b>7</b>
<b>HYDRAULIC SAFETY</b> .....	<b>7</b>
<b>TRANSPORT SAFETY</b> .....	<b>8</b>
<b>TO THE NEW OPERATOR OR OWNER</b> .....	<b>8</b>
<b>OPERATION</b> .....	<b>8</b>
<b>MOUNTING COUPLER</b> .....	<b>8</b>
<b>MAINTENANCE</b> .....	<b>9</b>
<b>BEFORE EVERY USE</b> .....	<b>9</b>
<b>EVERY WEEK</b> .....	<b>9</b>
<b>AFTER EVERY SEASON</b> .....	<b>9</b>
<b>HYDRAULIC SYSTEM</b> .....	<b>10</b>
<b>BOLT TORQUE</b> .....	<b>10</b>
<b>SPECIFICATION</b> .....	<b>11</b>
<b>SPECIFICATIONS &amp; CAPACITIES</b> .....	<b>11</b>
<b>PARTS LIST</b> .....	<b>12</b>
<b>EXCAVATOR BRUSH FLAIL MOWER ASSEMBLY</b> .....	<b>12</b>
<b>TMG-EFM32 PARTS LIST</b> .....	<b>12</b>
<b>TMG-EFM40 PARTS LIST</b> .....	<b>14</b>
<b>TMG-EFM48 PARTS LIST</b> .....	<b>16</b>

# IMPORTANT SAFETY INFORMATION

## Your Safety

YOU are responsible for the SAFE operation and maintenance of your TMG Excavator Brush Flail Mower. YOU must ensure that you and anyone else who is going to use, maintain or work around the Excavator Brush Flail Mower be familiar with the using and maintenance procedures and related SAFETY information contained in this manual. This manual will take you step-by-step through your working day and alerts you to all good safety practices that should be used while using the Excavator Brush Flail Mower.

Remember, YOU are the key to safety. Good safety practices not only protect you but also the people around you. Make these practices a working part of your safety program. Be certain that EVERYONE using this equipment is familiar with the recommended using and maintenance procedures and follows all the safety precautions. Most accidents can be prevented. Do not risk injury or death by ignoring good safety practices.

1. Excavator Brush Flail Mower owners must give operating instructions to operators or employees before allowing them to operate the machine, and at least annually thereafter.
2. The most important safety device on this equipment is a SAFE operator. It is the operator's responsibility to read and understand ALL Safety and Operating instructions in the manual and to follow these. Most accidents can be avoided.
3. A person who has not read and understood all using and safety instructions is not qualified to use the machine. An untrained operator exposes himself and bystanders to possible serious injury or death.
4. Do not modify the equipment in any way. Unauthorized modification may impair the function and/or safety and could affect the life of the equipment.
5. Think SAFETY! Work SAFELY!

## General Safety

1. Read and understand the Operator's Manual and all safety signs before using, maintaining, adjusting, or cleaning the Excavator Brush Flail Mower.
2. Have a first-aid kit available for use should the need arise and know how to use it.
3. Have a fire extinguisher available for use should the need arise and know how to use it.
4. Do not allow riders.
5. Wear appropriate protective gear. This list includes but is not limited to:

- A hard hat
- Protective shoes with slip resistant soles
- Heavy gloves



- Wet weather gear
- Hearing Protection



6. Install and secure all guards before starting.
7. Wear suitable ear protection for prolonged exposure to excessive noise.
8. Turn machine off, stop and disable engine, remove ignition key and place in your pocket, set park brake and wait for all moving parts to stop before servicing, adjusting, repairing, or unplugging.
9. Clear the area of people, especially small children, before using the unit.
10. Review safety related items annually with all personnel who will operating or maintaining the Excavator Brush Flail Mower.

### **Equipment Safety Guidelines**

1. Safety of the operator and bystanders is one of the main concerns in designing and developing equipment. However, every year many accidents occur which could have been avoided by a few seconds of thought and a more careful approach to handling equipment. You, the operator, can avoid many accidents by observing the following precautions in this section. To avoid personal injury or death, study the following precautions and insist those working with you, or for you to follow them.
2. In order to provide a better view, certain photographs or illustrations in this manual may show an assembly with a safety shield removed. However, equipment should never be used in this condition. Keep all shields in place. If shield removal becomes necessary for repairs, replace the shield prior to use.
3. Replace any safety sign or instruction sign that is not readable or is missing. Location of such safety signs is indicated in this manual.
4. Never use alcoholic beverages or drugs which can hinder alertness or coordination while using this equipment. Consult your doctor about using this machine while taking prescription medications.
5. Under no circumstances should young children be allowed to work with this equipment. Do not allow persons to use or assemble this unit until they have read this manual and have developed a thorough understanding of the safety precautions and of how it works. Review the safety instructions with all users annually.
6. This equipment is dangerous to children and persons unfamiliar with its operation. The operator should be a responsible, properly trained and physically able person familiar with machinery and trained in this equipment's operations. If the elderly are assisting with work, their physical limitations need to be recognized and accommodated.
7. Never exceed the limits of a piece of machinery.
8. If its ability to do a job, or to do so safely, is in question - DON'T TRY IT.
9. Do not modify the equipment in any way. Unauthorized modification may result in serious injury or death and may impair the function and life of the equipment.

10. In addition to the design and configuration of this implement, including Safety Signs and Safety Equipment, hazard control and accident prevention are dependent upon the awareness, concern, prudence, and proper training of personnel involved in the operation, transport, maintenance, and storage of the machine. Refer also to Safety Messages and operation instruction in each of the appropriate sections of the Excavator and machine manuals. Pay close attention to the Safety Signs affixed to the Excavator and the machine.

### **Safety Training**

1. Safety is a primary concern in the design and manufacture of our products. Unfortunately, our efforts to provide safe equipment can be wiped out by a single careless act of an operator or bystander.
2. In addition to the design and configuration of equipment, hazard control and accident prevention are dependent upon the awareness, concern, prudence, and proper training of personnel involved in the operation, transport, maintenance, and storage of this equipment.
3. It has been said, "The best safety feature is an informed, careful operator." We ask you to be that kind of an operator. It is the operator's responsibility to read and understand ALL Safety and Using instructions in the manual and to follow these. Accidents can be avoided.
4. If this machine is used by any person other than yourself, or is loaned or rented, it is the machine owner's responsibility to make certain that the operator, prior to using:
  - a. Reads and understands the operator's manuals.
  - b. Is instructed in safe and proper use.
5. Know your controls and how to stop the Excavator tractor and machine quickly in an emergency. Read this manual and the one provided with Excavator tractor.
6. Train all new personnel and review instructions frequently with existing workers. Be certain only a properly trained and physically able person will use the machinery. A person who has not read and understood all using and safety instructions is not qualified to use the machine. An untrained operator exposes himself and bystanders to possible serious injury or death. If the elderly is assisting with the work, their physical limitations need to be recognized and accommodated.

### **Safety Signs**

1. Always keep safety signs clean and legible.
2. Replace safety signs that are missing or have become illegible.
3. Replaced parts that displayed a safety sign should also display the current sign.
4. Safety signs have a part number in the lower righthand corner. Use this part number when ordering replacement parts.
5. Safety signs are available from your authorized Distributor or Dealer Parts Department or the factory.

## Safety Decals

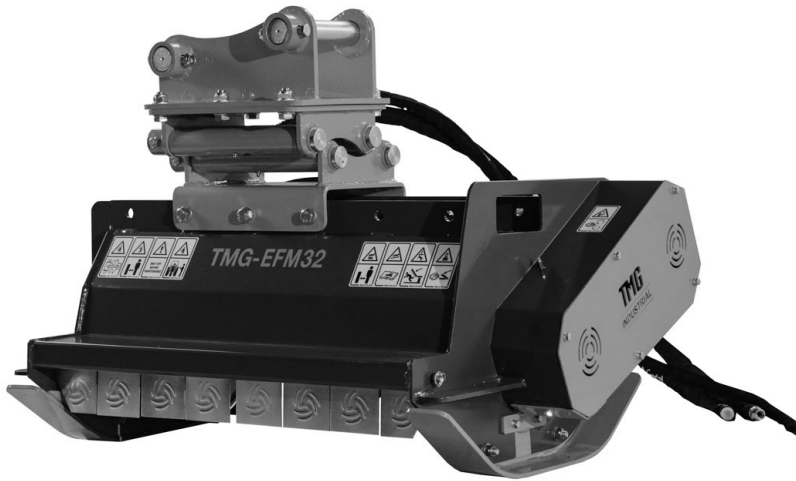

## Preparation

1. Never use the machine until you have read and completely understand this manual, the Excavator tractor Operator's Manual and each of the Safety Messages found on the safety signs on the Excavator tractor and machine.
2. Personal protection equipment including hard hat, safety glasses, safety shoes, and gloves are recommended during assembly, installation, operation, adjustment, maintaining, repairing, removal, cleaning, or moving the unit. Do not allow long hair, loose fitting clothing or jewelry to be around equipment.
3. **PROLONGED EXPOSURE TO LOUD NOISE MAY CAUSE PERMANENT HEARING LOSS!**
  - a) Power equipment with or without equipment attached can often be noisy enough to cause permanent, partial hearing loss. We recommend that you wear hearing protection on a full-time basis if the noise in the Operator's position exceeds 80db. Noise over 85db on a long-term basis can cause severe hearing loss. Noise over 90db adjacent to the Operator over a long-term basis may cause permanent, total hearing loss. NOTE: Hearing loss from loud noise (from tractors, chain saws, radios, and other such sources close to the ear) is cumulative over a lifetime without hope of natural recovery.
4. Clear working area of stones, branches or hidden obstacles that might be hooked or snagged, causing injury or damage.
5. Use only in daylight or good artificial light.
6. Be sure machine is properly mounted, adjusted and in good operating condition.
7. Ensure that all safety shielding, and safety signs are properly installed and in good condition.

## Maintenance Safety

1. Good maintenance is your responsibility. Poor maintenance is an invitation to trouble.
2. Follow good shop practices.
  - a) Keep service area clean and dry.
  - b) Be sure electrical outlets and tools are properly grounded.
  - c) Use adequate light for the job at hand.
3. Make sure there is plenty of ventilation. Never operate the engine of the towing vehicle in a closed building. The exhaust fumes may cause asphyxiation.
4. Before working on this machine, shut off the engine, set the brake, and turn fuel valve off.
5. Never work under equipment unless it is blocked securely.
6. Always use personal protection devices such as eye, hand and hearing protectors, when performing any service or maintenance work. Use heavy or leather gloves when handling blades.
7. Where replacement parts are necessary for periodic maintenance and servicing, genuine factory replacement parts must be used to restore your equipment to original specifications. The manufacturer will not be responsible for injuries or damages caused by use of unapproved parts and/or accessories.
8. A fire extinguisher and first aid kit should be kept readily accessible while performing maintenance on this equipment.
9. Periodically tighten all bolts, nuts and screws and check that all electrical and fuel connections are properly secured to ensure unit is in a safe condition.
10. When completing a maintenance or service function, make sure all safety shields and devices are installed before placing unit in service.



## Hydraulic Safety

1. Make sure that all the components in the hydraulic system are kept in good condition and are clean.
2. Before applying pressure to the system, make sure all components are tight, and that lines, hoses and couplings are not damaged.
3. Do not attempt any makeshift repairs to the hydraulic lines, fittings, or hoses by using tapes, clamps, or cements. The hydraulic system operates under extremely high pressure. Such repairs will fail suddenly and create a hazardous and unsafe condition.
4. Wear proper hand and eye protection when searching for a high-pressure hydraulic leak. Use a piece of wood or cardboard as a backstop instead of hands to isolate and identify a leak.



- If injured by a concentrated high-pressure stream of hydraulic fluid, seek medical attention immediately. Serious infection or toxic reaction can develop from hydraulic fluid piercing the skin surface.
- Relieve pressure on hydraulic system before maintaining or working on system.



### Transport Safety

- Comply with state and local laws governing safety and transporting of machinery on public roads.
- Check that all the lights, reflectors and other lighting requirements are installed and in good working condition.
- Do not exceed a safe travel speed. Slow down for rough terrain and cornering.
- Do not drink and drive.
- Be a safe and courteous driver. Always yield to oncoming traffic in all situations, including narrow bridges, intersections, etc. Watch for traffic when operating near or crossing roadways.

### To the New Operator or Owner

Follow all safety instructions exactly. Safety is everyone's business. By following recommended procedures, a safe working environment is provided for the operator, bystanders, and the area around the worksite. Untrained operators are not qualified to operate the machine.

Many features incorporated into this machine are the result of suggestions made by customers like you. Read this manual carefully to learn how to use the chipper safely and how to set it to provide maximum field efficiency. By following the using instructions in conjunction with a good maintenance program, your Excavator Brush Flail Mower will provide many years of trouble-free service.

## OPERATION

### Mounting coupler

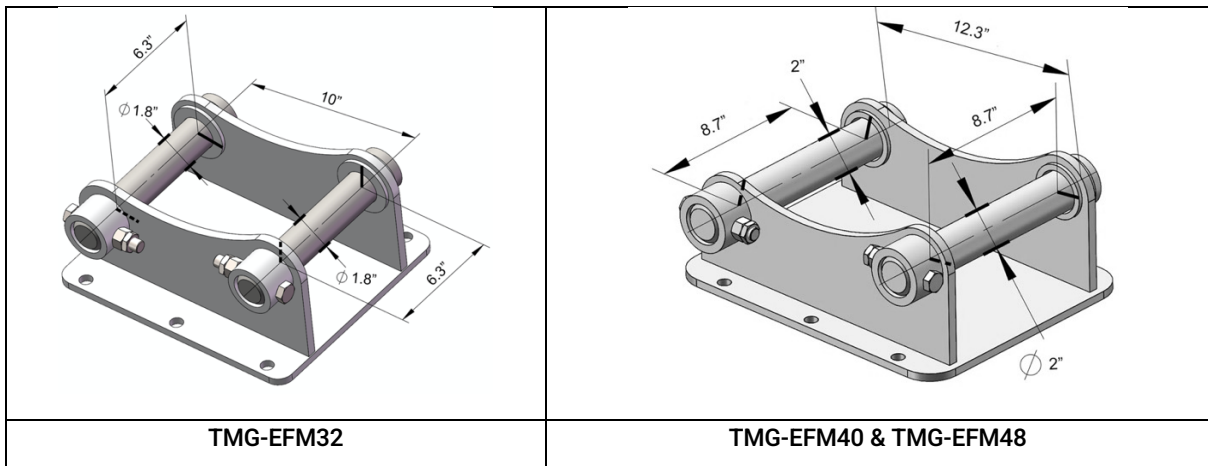



## High Attention!

A case drain line (3rd hose line--3/8") is required to be added prior to use of this attachment. The case drain line will relieve the excess pressure and drain it back to your return line, then into the reservoir. Without a case drain line installed properly, that extra pressure will blow a seal or damage your hydraulic line.

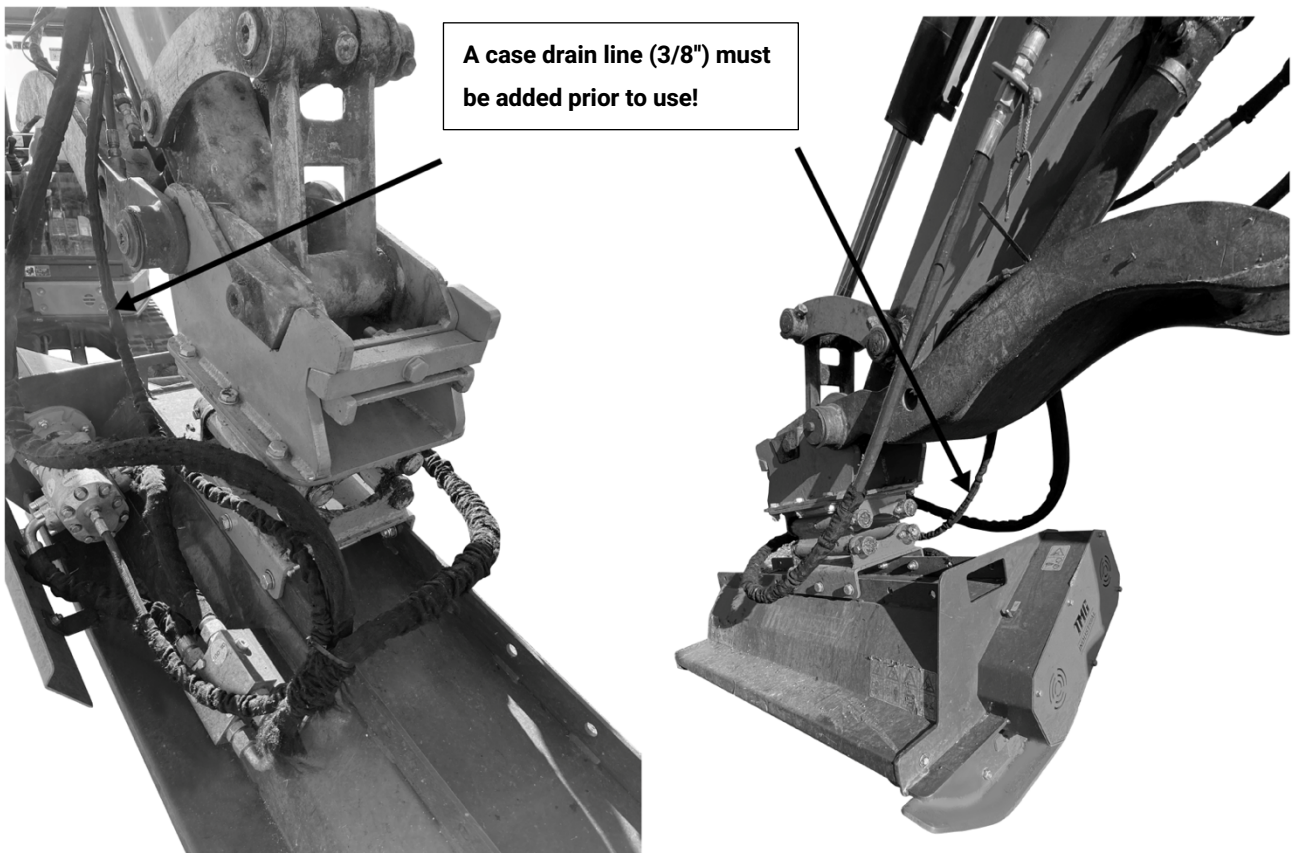

# MAINTENANCE

## Before Every Use

Check hydraulic hoses and fittings daily for leaks. Replace hose if worn or damaged. Investigate the location of any oil leaks and repair. Lubricate all joints with lithium grease.

Inspect the unit for any buildup of contamination (dirt, stones, etc.).

Check cutting teeth every 2 hours of use. Keep cutting teeth in good condition. Unit will cut faster and remaining teeth will last longer if broken teeth are replaced.

Check that all fasteners (nuts, bolts, pins, keepers) are in their right place and are tight. Inspect and replace any worn, torn, or missing safety decals.

## Every Week

Check the condition of the blade and belts. Order parts if the blades are becoming worn and replace as soon as possible.

## After Every Season

Inspect the implement for any loose or worn parts that may need to be replaced prior to the next season.

Visually inspect the blades. Replace, if necessary.

Clean, sand & repaint any area that looks worn or scratched to prevent further rusting. Use an equipment-paint found at your local hardware store or building center.

Replace any warning decals that have been lost or damaged.

Store your implement in a shed or cover with a water-proof tarp to protect it from the weather. Store in an area not frequented by children.

**WARNING!**

To avoid an accident that could result in Death or Serious Injury, never find yourself in a position where any body part is located under an unsupported blade or frame when servicing this attachment.

**WARNING!**

Hazardous dust can be generated if painted surfaces are heated or welded and could result in death or Serious Injury. Remove paint before welding and always make repairs in a well-ventilated area and wear an approved respirator.

**Hydraulic System**

**WARNING!**

A small stream of oil from a pinhole leak could penetrate your skin if contacted. To avoid an accident that could result in Death or Serious Injury, never use your hand or other body parts in an attempt to locate a hydraulic leak.

**NOTICE!**

Always release the hydraulic system pressure from the hydraulic circuits prior to removing the attachment or any hydraulic system service work.

**Bolt Torque**

**CHECKING BOLT TORQUE**

The tables shown below give correct torque values for various bolts and cap screws. Tighten all bolts to the torques specified in chart unless otherwise noted. Check tightness of bolts periodically, using bolt torque chart as a guide. Replace hardware with the same strength bolt.

Torque figures indicated above are valid for non-greased or non-oiled threads and heads unless otherwise specified. Therefore, do not grease or oil bolts or cap screws unless otherwise specified in this manual. When using locking elements, increase torque values by 5%.

\* Torque value for bolts and cap screws are identified by their head markings

**ENGLISH TORQUE SPECIFICATIONS**

Bolt Diameter "A"	Bolt Torque*					
	SAE 2 (N.m) (lb-ft)		SAE 5 (N.m) (lb-ft)		SAE 8 (N.m) (lb-ft)	
1/4"	8	6	12	9	17	12
5/16"	13	10	25	19	36	27
3/8"	27	20	45	33	63	45
7/16"	41	30	72	53	100	75
1/2"	61	45	110	80	155	115
9/16"	95	60	155	115	220	165
5/8"	128	95	215	160	305	220
3/4"	225	165	390	290	540	400
7/8"	230	170	570	420	880	650
1"	345	225	850	630	1320	970

**METRIC TORQUE SPECIFICATIONS**

Bolt Diameter "A"	Bolt Torque*			
	8.8 (N.m) (lb-ft)		10.9 (N.m) (lb-ft)	
M3	.5	.4	1.8	1.3
M4	3	2.2	4.5	3.3
M5	6	4	9	7
M6	10	7	15	11
M8	25	18	35	26
M10	50	37	70	52
M12	90	66	125	92
M14	140	103	200	148
M16	225	166	310	229
M20	435	321	610	450
M24	750	553	1050	774
M30	1495	1103	2100	1550
M36	2600	1917	3675	2710

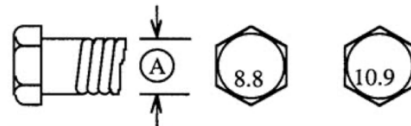
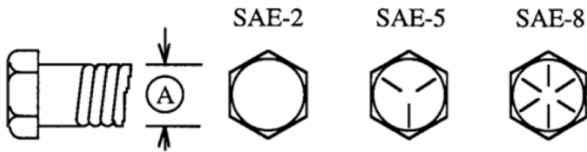

# SPECIFICATION

**Specifications & Capacities**

- Hydraulic motor with oil-in, oil-out, drain port
- Self-levelling Kit
- Adjustable skid shoes
- Belt drive transmission
- High performance cutter drum
- Mounting coupler included

	TMG-EFM32	TMG-EFM40	TMG-EFM48
Excavator	3-5-ton	6-8-ton	6-8-ton
Max Cutting capacity:	4"	4"	4"
Working Width	32"	40"	48"
Number of Cutting Teeth	14	16	18
Hydraulic Flow	10-16 GPM	16-21 GPM	16-21 GPM
Hydraulic system pressure	2900 PSI	2900 PSI	2900 PSI
Product Weight	680 lb	730 lb	750 lb

# PARTS LIST

## Excavator Brush Flail Mower Assembly

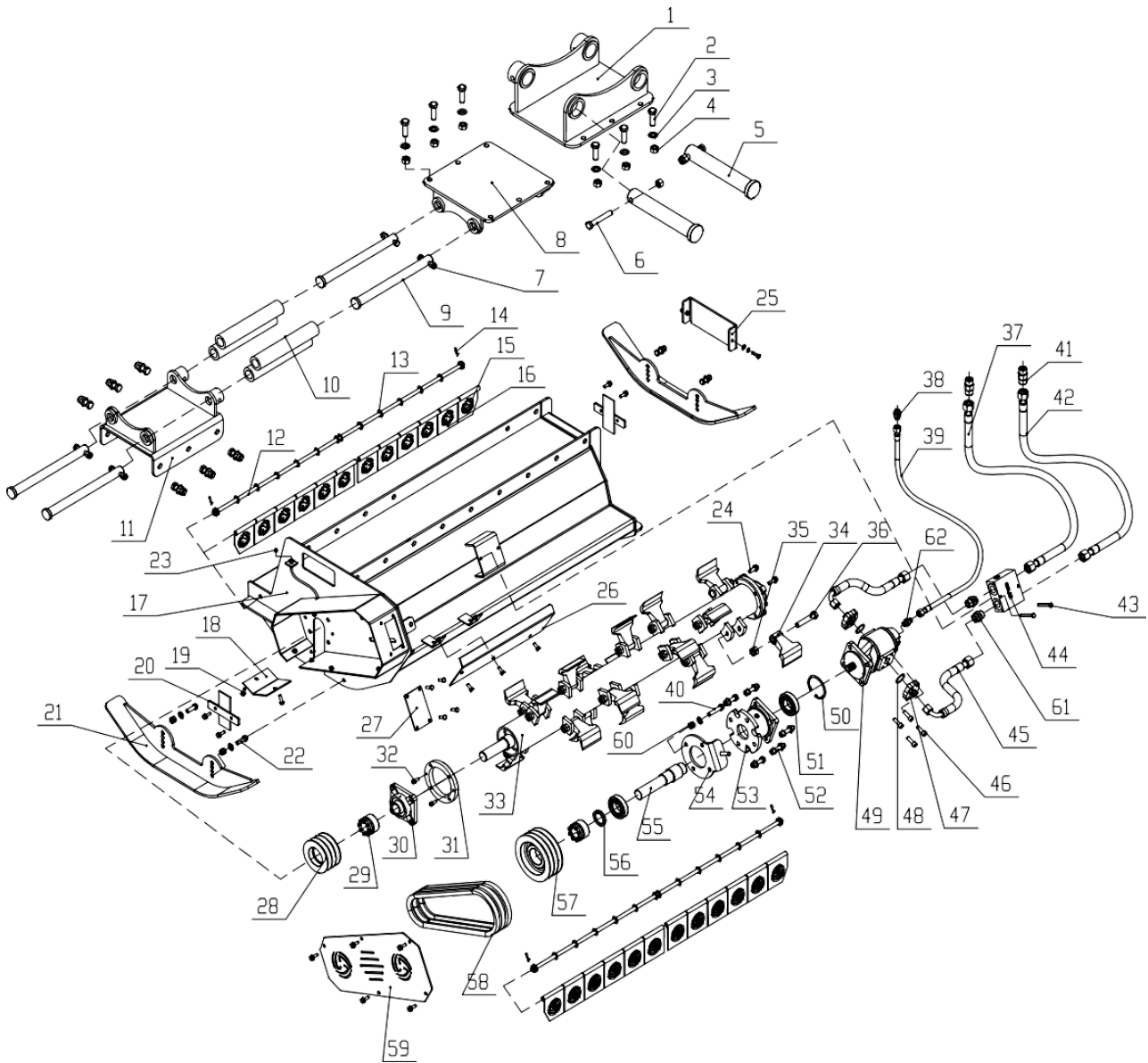

### TMG-EFM32 Parts List

Part No.	Ref.	Part Description	QTY
1	EXF800.2TMG	Hook weldment	1
2	GB/T 5783	Bolt M16*50	12
3	GB/T 97.1	Washer 16	14
4	GB/T 889.1	Locking Nut M16	20
5	EXF800.18	Pin	2
6	GB/T 5782	Bolt M16*100	2
7	GB/T 5782	Bolt M12*70	4
8	EXF800.3	Connection weldment 03	1
9	EXF1200.19	Pin 03	4
10	EXF1200.4	Connection weldment 04	1

11	EXF1200.5	Connection weldment 05	1
12	EXF800.20	Shaft bar	2
13	GB/T 97.1	Washer 12	48
14	B-G06172A-12	Nut M12	8
15	EF100.00.122AH/BH	Fender	4
16	EF100.00.122H	Wide fender	12
17	EXF800.1	Mower deck	1
18	EXF1200.14	Belt cover plate	1
19	GB/T 5783	Bolt M8*20	16
20	EXF1200.10	Cover weldment	2
21	EXF1200.6	Skid shoes weldment	2
22	GB/T 5783	Bolt M12*30	4
23	JB/T 7940.1	Grease nipple M6	4
24	GB/T 5783	Bolt M12*45	8
25	EXF1200.15	Bearing cover	1
26	EXF1200.12	Motor protection plate	1
27	EXF1200.13	Up belt cover	1
28	EXF800.27	Small pulley	1
29	B-J7943Z3-35*60	Sleeve REACH Z3-35*60	2
30	GB/T 7810	Bearing UCFU207	2
31	EXF1200.9	Protect cover	2
32	GB/T 70.1	Bolt M8*25	4
33	EXF800.8	Blade axle weldment	1
34	EFGC175.32	Hammer	14
35	GB/T 889.2	Locking Nut M16*1.5	14
36	GB/T 5785	Bolt M16*1.5*85	14
37	EXF800.21.2TMG	Oil pipe 01 M22*1.5 NPT1/2 Length:2000mm	1
38	EXF1200.21.3TMG	Connection NPT 3/8	1
39	EXF1200.21.4TMG	Oil pipe 02 M14*1.5 NPT3/8 Length:2200mm	1
40	GB/T 5783	Bolt M12*50	4
41	EXF1200.21.1TMG	Connection NPT 1/2	2
42	EXF800.21.1TMG	Oil pipe 03 M22*1.5 NPT1/2 Length:2000mm	1
43	GB/T 5782	Bolt M8*60	2
44	EXF800.22	Valve	1
45	EXF800.21.3	Oil pipe 04 M22*1.5 F44.4 Length:450mm	2
46	GB/T 70.1	Bolt M10*30	8
47	W-05-FH34	SAE Split flange	2

48	AS 568	O rings 219	2
49	CMGh2025-BFΦS	Gear motor	1
50	GB/T 893.1	Circlip 80	1
51	GB/T 276	Bearing 6208-Z	2
52	GB/T 70.1	Hex Bolt M12*50	4
53	LM180.17-1	Coupling housing	1
54	EXF1200.7	Tension plate	1
55	EXF1200.17-1	Coupling shaft	1
56	GB/T 1387.1	Oil seal 40*55*8	1
57	EFGC155.31	Big pulley	1
58	B-G12732017*1041	Belt AV17*1041	3
59	EXF1200.11TMG	Belt cover	1
60	GB/T 889.1	Locking Nut M12	16
61	GE15LR1/2ED	Connector M22*1.5-G1/2	4
62	GE08LR3/8ED	Connector M14*1.5-G3/8	2

#### TMG-EFM40 Parts List

Part No.	Ref.	Part Description	QTY
1	EXF1200.2TMG	Hook weldment	1
2	GB/T 5783	Bolt M16*50	12
3	GB/T 97.1	Washer 16	14
4	GB/T 889.1	Locking Nut M16	20
5	EXF1200.18	Pin	2
6	GB/T 5782	Bolt M16*100	2
7	GB/T 5782	Bolt M12*70	4
8	EXF1200.3	Connection weldment 03	1
9	EXF1200.19	Pin 03	4
10	EXF1200.4	Connection weldment 04	1
11	EXF1200.5	Connection weldment 05	1
12	EXF1000B.20	Shaft bar	2
13	GB/T 97.1	Washer 12	48
14	B-G06172A-12	Nut M12	8
15	EF100.00.122AH/BH	Fender	4
16	EF100.00.122H	Wide fender	16
17	EXF1000.1	Mower deck	1
18	EXF1200.14	Belt cover plate	1

19	GB/T 5783	Bolt M8*20	16
20	EXF1200.10	Cover weldment	2
21	EXF1200.6	Skid shoes weldment	2
22	GB/T 5783	Bolt M12*30	4
23	JB/T 7940.1	Grease nipple M6	4
24	GB/T 5783	Bolt M12*45	8
25	EXF1200.15	Bearing cover	1
26	EXF1200.12	Motor protection plate	1
27	EXF1200.13	Up belt cover	1
28	EFGC155.27	Small pulley	1
29	JB/T 11544	Sleeve REACH 04	2
30	GB/T 7810	Bearing UCFU207	2
31	EXF1200.9	Protect cover	2
32	GB/T 70.1	Bolt M8*25	4
33	EXF1000B.8A	Blade axle weldment	1
34	EFGC175.32	Hammer	16
35	GB/T 889.2	Locking Nut M16*1.5	16
36	GB/T 5785	Bolt M16*1.5*85	16
37	EXF1200.21.2TMG	Oil pipe 01 M27*1.5 NPT1/2 Length:2000mm	1
38	EXF1200.21.3TMG	Connection NPT 3/8	1
39	EXF1200.21.4TMG	Oil pipe 02 M14*1.5 NPT3/8 Length:2200mm	1
40	GB/T 5783	Bolt M12*50	4
41	EXF1200.21.1TMG	Connection NPT 1/2	2
42	EXF1200.21.5TMG	Oil pipe 03 M27*1.5 NPT1/2 Length:2000mm	1
43	GB/T 5782	Bolt M8*60	2
44	EXF1200.22	Valve	1
45	EXF1200.21.6	Oil pipe 04 M27*1.5 F44.4 Length:450mm	2
46	GB/T 70.1	Bolt M10*30	8
47	W-05-FH34	SAE Split flange	2
48	AS 568	O rings 219	2
49	CMGh2040-BFΦS	Gear motor	1
50	GB/T 893.1	Circlip 80	1
51	GB/T 276	Bearing 6208-Z	2
52	GB/T 70.1	Hex Bolt M12*50	4
53	LM180.17-1	Coupling housing	1
54	EXF1200.7	Tension plate	1
55	EXF1200.17-1	Coupling shaft	1

56	GB/T 1387.1	Oil seal 40*55*8	1
57	EFGC155.31	Big pulley	1
58	B-G12732017*1016	Belt AV17*1016	3
59	EXF1200.11TMG	Belt cover	1
60	GB/T 889.1	Locking Nut M12	16
61	GE18LR3/4ED	Connector M27*1.5-G3/4	4
62	GE08LR3/8ED	Connector M14*1.5-G3/8	2

#### TMG-EFM48 Parts List

Part No.	Ref.	Part Description	QTY
1	EXF1200.2TMG	Hook weldment	1
2	GB/T 5783	Bolt M16*50	12
3	GB/T 97.1	Washer 16	14
4	GB/T 889.1	Locking Nut M16	20
5	EXF1200.18	Pin	2
6	GB/T 5782	Bolt M16*100	2
7	GB/T 5782	Bolt M12*70	4
8	EXF1200.3	Connection weldment 03	1
9	EXF1200.19	Pin 03	4
10	EXF1200.4	Connection weldment 04	1
11	EXF1200.5	Connection weldment 05	1
12	EXF1200B.20	Shaft bar	2
13	GB/T 97.1	Washer 12	48
14	B-G06172A-12	Nut M12	8
15	EF100.00.122AH/BH	Fender	4
16	EF100.00.122H	Wide fender	20
17	EXF1200.1	Mower deck	1
18	EXF1200.14	Belt cover plate	1
19	GB/T 5783	Bolt M8*20	16
20	EXF1200.10	Cover weldment	2
21	EXF1200.6	Skid shoes weldment	2
22	GB/T 5783	Bolt M12*30	4
23	JB/T 7940.1	Grease nipple M6	1
24	GB/T 5783	Bolt M12*45	8
25	EXF1200.15	Bearing cover	1
26	EXF1200.12	Motor protection plate	1



27	EXF1200.13	Up belt cover	1
28	EFGC155.27	Small pulley	1
29	JB/T 11544	Sleeve REACH 04	2
30	GB/T 7810	Bearing UCFU207	2
31	EXF1200.9	Protect cover	2
32	GB/T 70.1	Bolt M8*25	4
33	EXF1200B.8	Blade axle weldment	1
34	EFGC175.32	Hammer	18
35	GB/T 889.2	Locking Nut M16*1.5	18
36	GB/T 5785	Bolt M16*1.5*85	18
37	EXF1200.21.2TMG	Oil pipe 01 M27*1.5 NPT1/2 Length:2000mm	1
38	EXF1200.21.3TMG	Connection NPT 3/8	1
39	EXF1200.21.4TMG	Oil pipe 02 M14*1.5 NPT3/8 Length:2200mm	1
40	GB/T 5783	Bolt M12*50	4
41	EXF1200.21.1TMG	Connection NPT 1/2	2
42	EXF1200.21.5TMG	Oil pipe 03 M27*1.5 NPT1/2 Length:2000mm	1
43	GB/T 5782	Bolt M8*60	2
44	EXF1200.22	Valve	1
45	EXF1200.21.6	Oil pipe 04 M27*1.5 F44.4 Length:450mm	2
46	GB/T 70.1	Bolt M10*30	8
47	W-05-FH34	SAE Split flange	2
48	AS 568	O rings 219	2
49	CMGh2040-BFΦS	Gear motor	1
50	GB/T 893.1	Circlip 80	1
51	GB/T 276	Bearing 6208-Z	2
52	GB/T 70.1	Hex Bolt M12*50	4
53	LM180.17-1	Coupling housing	1
54	EXF1200.7	Tension plate	1
55	EXF1200.17-1	Coupling shaft	1
56	GB/T 1387.1	Oil seal 40*55*8	1
57	EFGC155.31	Big pulley	1
58	B-G12732017*1016	Belt AV17*1016	3
59	EXF1200.11TMG	Belt cover	3
60	EXF1200.11TMG	Belt cover	1
61	GE18LR3/4ED	Connector M27*1.5-G3/4	4
62	GE08LR3/8ED	Connector M14*1.5-G3/8	2